

# **DZ40 display**

## **Functional specification**

Product name: Intelligent LCD display

Product number: DZ40

	sign	date
authorized strength		
check		
approve		

---

# CONTENT

I Product introduction.....	3
1 Product name and model.....	3
2 Product introduction.....	3
3 serviceable range.....	3
4 Appearance and size.....	3
5 Display coding rule.....	4
II product description.....	5
1 Specification parameter.....	5
2 Functional overview.....	5
3 Installation mode.....	5
4 Display interface.....	6
4.1 shutdown display.....	6
4.2 Normal riding state.....	6
5 Key definition.....	7
6 Function operation.....	7
6.1 On/off.....	7
6.2 Power shift switch.....	7
6.3 assist carry out.....	7
6.4 Headlights on (brightness switching).....	8
6.5 Electric quantity display.....	8
7 User setting.....	9
7.1 Enter setting.....	9
7.2 Unit setting.....	9
7.3 Wheel diameter information.....	10
7.3 Speed limit information.....	10
7.3 battery voltage.....	10
8 Fault information.....	11
8.1 Fault display.....	11
8.2 Fault code definition.....	11
9 Define wiring.....	12
III matters need attention.....	12

# **I. Product introduction**

## **1 Product name and model**

Intelligent LCD display, model: DZ40

## **2 Product introduction**

- ◇ Simple and light, left switch display, and can be used with middle display.
- ◇ High brightness white digital tube display
- ◇ Excellent outdoor design IP65 waterproof ability
- ◇ Serial communication interface, convenient maintenance service

## **3 Scope of use**

EN15194 electric power-assisted bicycle

## **4 Appearance and size**

The outer shell material of the product is ABS, and the upper shell window is made of high hardness brown PC.



#### 4.1 Display overall dimensions

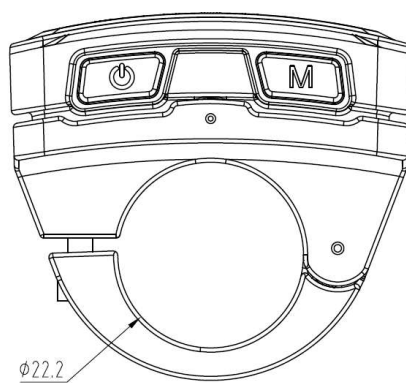
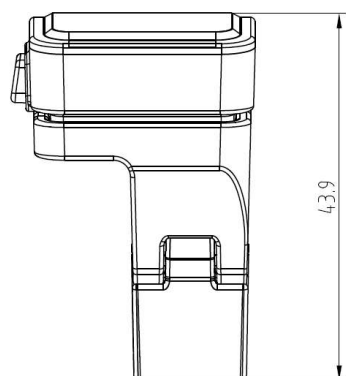
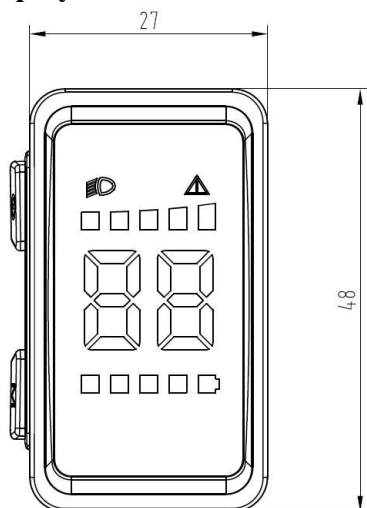

## 5 Display coding rules



SW102 product model (this information is not listed in barcode information);

C manufacturer code or production team code;

S2 product model code;

C01 indicates the number of weeks in the production year;

B indicates the hardware version;

101 indicates the firmware version number;

001 indicates the serial number of the product.

## II. Product description

### 1 specification parameters

①Power supply: DC 24V/36V/48V

②Rated current: 18mA/36V

③Shutdown leakage current: < 1uA;

④Display: white digital tube display

⑤Communication mode: UART (default)

⑥Operating temperature:-20 C ~ 60 C

⑦Storage temperature:-30 C ~ 80 C

⑧Waterproof grade: IP65

## **2 Functional overview**

- ① Four keys, easy to operate
- ② Speed display: real-time speed
- ③ Gear control: default gear 0-5.
- ④ Level 6 power indicator: 1-5 power levels, and under-voltage prompt.
- ⑤ Power-boosting function
- ⑥ Headlight indication: Headlight switch status indication (supported by controller)
- ⑦ Fault code indication

## **3 Installation method**

① Open the locking clamp of the display, put it on the left handlebar (standard handle pipe specification:  $\varnothing 22.2$ ), adjust it to an easy-to-operate position, and fix and tighten the fixing screw with M3 hexagon socket. Locking torque: 0.8N.m \* Display damage caused by excessive torque is not covered by warranty.

② Connect the display connector 5pin plug-in to the controller docking connector as indicated.

## **4 display interface**

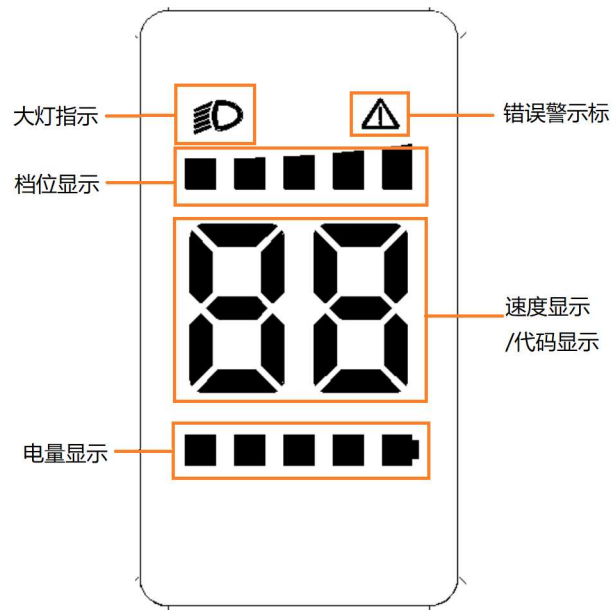

#### 4.1 boot display

Show the start-up character pen segment as a marquee effect, and then the pen segment will flash for 2 times.

#### 4.2 Riding interface

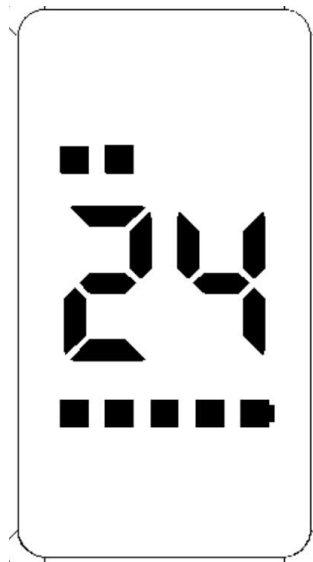

①Gear indication: 0-5 gear, gear indication.

②Speed display: Real-time speed display.

③Electricity quantity indication: Level 6 electricity quantity indication: Level 1-5 electricity quantity and under-voltage indication (1 light flashes).

## 5 key definition

**On/off:** ⏻, **function keys:** M, **adjustment key+:** upper part of the display display area (explained by ^), **adjustment key-:** lower part of the display display area (explained by v).

## 6 functional operation

### 6.1 On/Off

Keep the normal connection state between the display and the controller, press the ⏻ key for 2 seconds when the display is turned off, and the display will fully display the startup interface, then enter the basic interface normally and start working; Long press the ⏻ (2 seconds) in the power-on state, and the display will turn off. If the rider does not operate the meter for 5 minutes (default) (and the speed is 0), the meter will automatically turn off.

### 6.2 Power shift switch

Press the ^ key or the v key to switch the power-assisted gear and change the power-assisted mode.

There are four modes: 0/ low/medium/high gear.

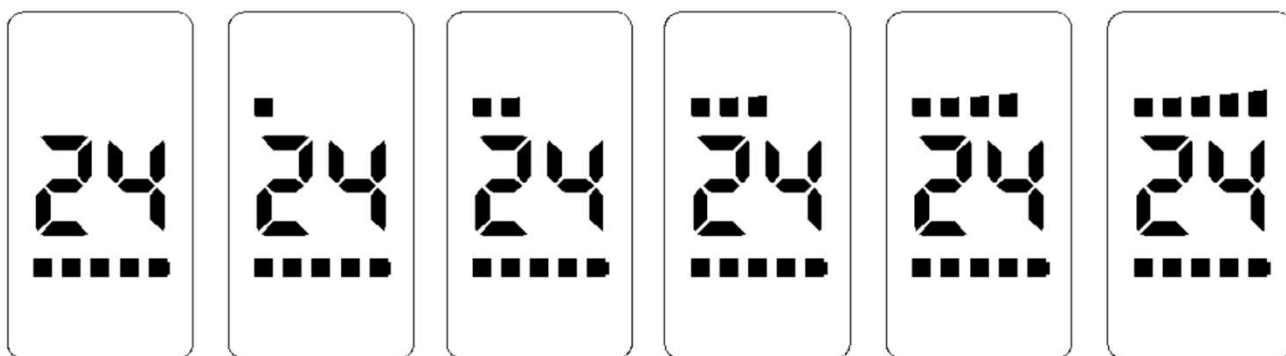

0, 1, 2, 3, 4 and 5

### 6.3 Help implement

Press the v key for 2 seconds, and then enter the state of boosting implementation. Release the



▼key, that is, quit boosting.

Implementation mode.

#### 6.4 Headlights on (brightness switching)

Press the ^key for a long time, and after 1 second, the headlights turn on (with the support of the controller), the lights icon lights up, and the brightness of the display lights decreases. Press the ^key for a long time again, and after 1 second, the headlights turn off and the display brightness recovers.

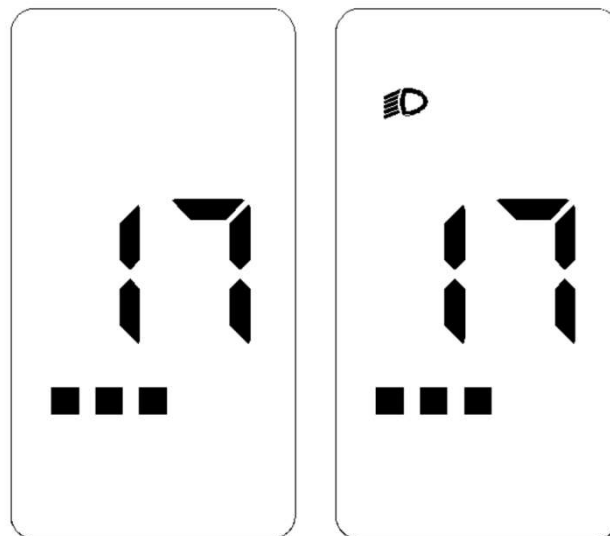

Turn off the lights (high brightness) and turn on the lights (low brightness)

#### 6.5 Power display

When the battery charge is normal, the 5-segment LCD of the battery displays the charge according to the time and the outer frame lights up. When the battery runs out of power, the 5-segment LCD of the battery completely goes out and the outer frame flashes, so it needs to be charged immediately. The battery charge is shown in the following figure:

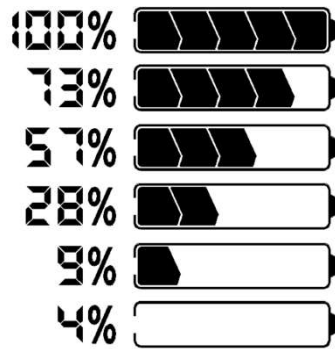

Battery charge (C) displays the corresponding table (the charge indication can be adjusted according to the demand)

serial number	On the display (SOC)	Display on the meter	Voltage (24V)	Voltage (36V)	Voltage (48V)
one	$C \leq 5\%$	Battery outer frame flashing	$U \leq 23.1$	$U \leq 33$	$U \leq 42.9$
2	$5\% < C < 15\%$	One-grid quantity	$23.1 < U < 24.5$	$33 < U < 34.7$	$42.9 < U < 45.1$
three	$15\% \leq C < 35\%$	Two-grid quantity	$24.5 \leq U < 25.1$	$34.7 \leq U < 35.8$	$45.1 \leq U < 46.5$
four	$35\% \leq C < 55\%$	Three-grid quantity	$25.1 \leq U < 25.6$	$35.8 \leq U < 36.7$	$46.5 \leq U < 47.5$
five	$55\% \leq C < 75\%$	Four-grid power	$25.6 \leq U < 27$	$36.7 \leq U < 38.5$	$47.5 \leq U < 50.1$
six	$C \geq 75\%$	Five grid quantity	$U \geq 27$	$U \geq 38.5$	$U \geq 50.1$



## 7 User Settings

**Settings: unit settings, \* wheel diameter information, \* speed limit information, \* battery voltage, (items marked with \* are fixed display items, and user setting options are not provided)**

### 7.1 Enter the settings

- ✧ Within 10 seconds of starting the machine, press and hold the **M**(2 seconds) for a long time, and the system will enter the user setting interface, where relevant parameters can be set and viewed.
- ✧ Press long **M**(2 seconds) to exit and save the setting status.
- ✧ In the user interface setting state, if it is not operated for 10 seconds, the display will return to

the normal riding state without saving the parameter settings.

✧ In the user interface state, in the setting item, briefly press / to switch the setting content.

## 7.2 Unit Settings

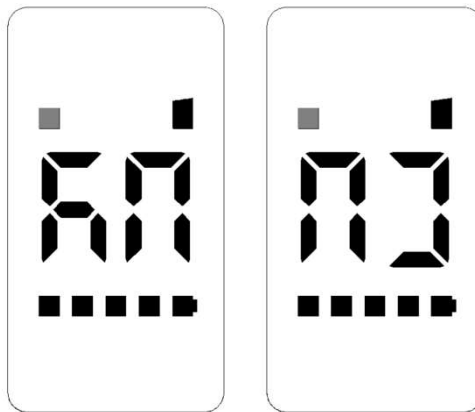

Enter the setting interface (default unit setting item: the first gear segment flashes, and the fifth gear segment stays on).

You can check the metric KM/ imperial m switching of unit mode, and the factory default value is KM. (7-segment LED standard alphabet is adopted)



Metric (KM) English (MI)

## 7.3 Wheel diameter information

After entering the setting interface, briefly press the / switch setting content to enter the

**wheel diameter information (the second segment of gear flashes, and the fifth end stays on).**

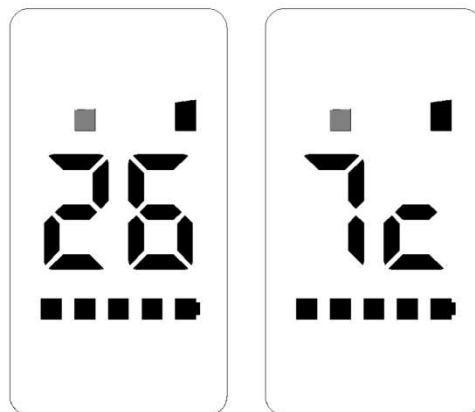

You can check the wheel diameter information (700C is used instead of 7c, 27.5 is used instead of 27).



26inch

700C

### 7.3 speed limit information

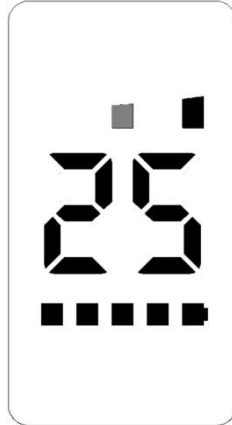

After entering the setting interface, briefly press the / switch setting content to enter the **wheel diameter information (the third gear segment flashes, and the fifth gear segment stays on).**

Check the speed limit information (the default speed limit is 25km/h).



The speed limit is 25 km/h

### 7.3 Battery voltage

After entering the setting interface, briefly press the / switch setting content to enter the **battery voltage check (the fourth segment of gear flashes, and the fifth end stays on).**

You can view the collected battery voltage information (two digits, decimal places rounded).

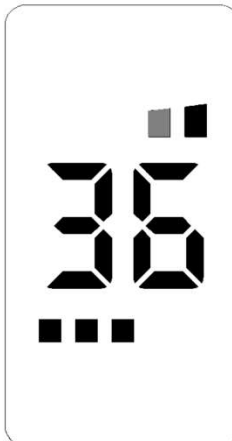

Voltage 36V

## 8 Fault information

### 8.1 Fault display

The fault icon and fault code are displayed, and the fault code flashes.

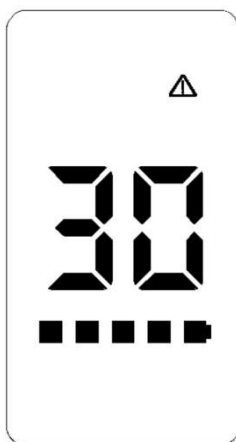

Error 30

### 8.2 definition of fault code

The fault code is obtained from the controller instruction. Generally, the controller defines the meaning of the error code. The meter only defines the unreachable ERROR 30.

Fault code	Fault description	Investigation and analysis
E30	Communication failure, the display can't receive the data from the controller or the received data is wrong data.	<ol style="list-style-type: none"><li>1: Check whether the TX and RX communication lines are connected correctly.</li><li>2. Check whether the harness and connectors are loose or broken.</li><li>3. Check whether the display communication protocols match.</li></ol>

## 9 Connection definition

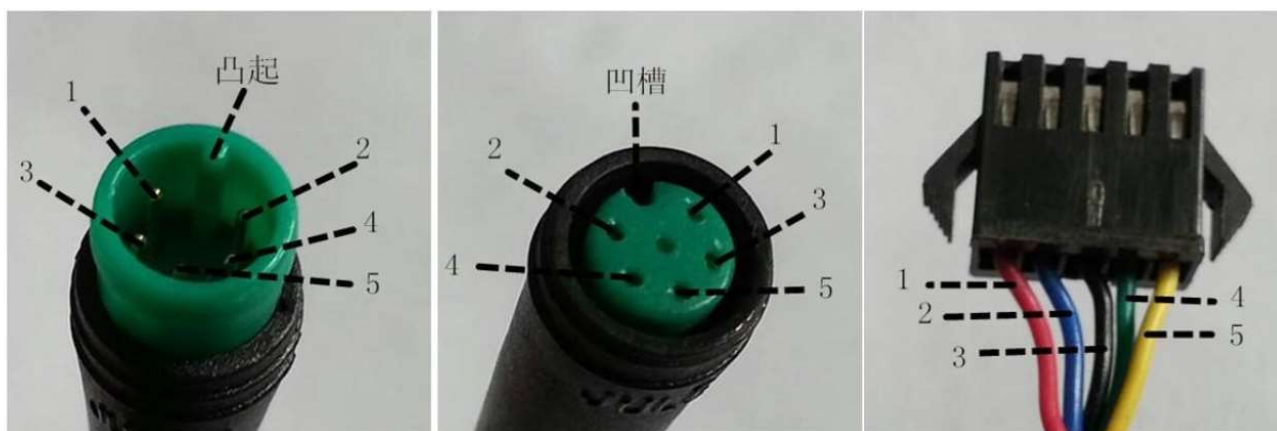

The outlet terminal of the display is connected with the terminal of the controller.

Table 1 Standard connector wire sequence table

Standard line sequence	Standard line color	function
one	Red (VCC)	Display power cord
2	Blue (Kp)	Power control line of controller
three	Black (GND)	Display ground wire
four	Green (RX)	Data receiving line of display
five	Yellow (TX)	Data transmission line of display

**Note:** The leads of some products are waterproof plug-ins, so users can't see the color of the leads in the harness.

### III. Matters needing attention

- ✧ During use, pay attention to safety, and don't plug and unplug the display when it is powered on.
- ✧ Try to avoid using it in harsh environment, such as heavy rain, heavy snow and exposure.
- ✧ When the display cannot be used normally, it should be sent for repair as soon as possible.